

# Kanadyjski Ram-Kangaroo Mk. I

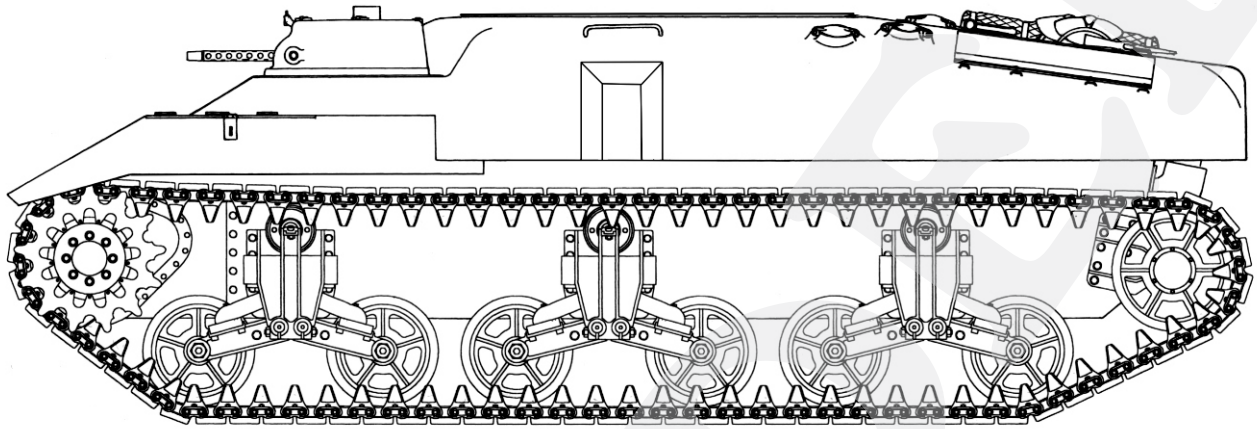

„Ram-Kangaroo” był jednym z pierwszych prawdziwym Opancerzonym Transporterem Piechoty APC (Armoured Personnel Carrier). Była to modyfikacja kanadyjskiego czołgu średniego „Ram” Mk. I z bocznymi drzwiami lub Mk. I bez bocznych drzwi. Ram-Kangaroo okazał się bardzo popularnym transporterem, mógł przewozić od 8 do 11 żołnierzy plus dwóch członków załogi(max. 20 osób).

Od września 1944 roku używany w 1 Canadian Armored Carrier Regiment oraz British 49th Armored Personnel Carrier Regiment, używany był do końca wojny

## Dane techniczno-taktyczne:

- załoga	2 osób + 8-11 żołnierzy
- wymiary (dł./szer./wys.)	5800/2670/1850
- uzbrojenie	1 km Browning
- silnik	Continental R975 C1, gwiazdowy, 9-cio cylindrowy
- prędkość max	38 km/h
- zasięg	190 km

Based on the Canadian "RAM", the "Kangaroo" represents the first real Armored Personnel Carrier, although Priests and Sherman had been converted for the APC role earlier in Italy and in the Normandy Campaign. Introduced in Sept.'44, they were issued to the 1ste Canadian Armored Carrier Regiment and the British 49th Armored Personnel Carrier Regiment, both regiments being absorbed in December into the 79th Armored Division. Proving to be very popular, they could carry an Infantry Section of eight men. The 79th Arm. Division used 300 Kangaroos in operations in N.W. Europe from December 1944 until the end of hostilities.

## Technical data:

- crew	2 + 8-11
- lenght/width/height	5800/2670/1850
- armament	1 MG Browning
- engine	Continental R975 C1, 9 cylindre, radial, air cooled
- max. speed	24 mph (on roads)
- max. range	120 miles

